



XXI/Avanti/Stealth SERIES

Operational Manual

July 2004

Table of Contents



XXI/Avanti/Stealth SERIES *Operational Manual*

SECTION I

IMPORTANT SAFETY INSTRUCTIONS

SECTION II *BEFORE USE*

- 2-1 Working Pressure
- 2-2 Hydraulic Connections
- 2-3 Electrical Connections
- 2-4 Air Connections

SECTION III *OPERATION*

- 3-1 General
- 3-2 Connecting the System
- 3-3 Drive Direction Change
- 3-4 Reaction Arm XXI/Avanti
- 3-5 Setting Torque
- 3-6 Setting Pump Pressure
- 3-7 Tightening Procedures
- 3-8 Operating the XXI, Avanti & Stealth Systems
- 3-9 Loosening Procedures

SECTION IV *USE WITH LoaDISC* *WASHER & CLAMP-NUT*

- 4-1 Tool set up and operation
- 4-2 LoaDISC Tensioning
- 4-3 LoaDISC De-tensioning
- 4-4 LoaDISC Lubrication
- 4-5 CLAMP-NUT Tensioning
- 4-6 Clamp-nut De-tensioning
- 4-7 Clamp Lubrication

SECTION V *OPERATION* *HYTORC POWER PACKS*

- 5-1 General Information
- 5-2 Hydraulic Connections
- 5-3 Prior to Use
- 5-4 Operation –Electric Pump--
- 5-5 Operation –Air Pump--
- 5-6 Automatic Pump
- 5-7 Starting with Automatic System

SECTION VI *HELPFUL* *INFORMATION*

- Tool Dimensions & Parts List
- Field-proven Torquing Procedure
- Pressure/Torque & Pressure/Load Conversion Chart
- Recommended Torque For ASTM A193 Grade B7 Studs

INTRODUCING THE NEW GENERATION HYTORC



Thank you for buying the NEW HYTORC FREEDOM-LINE!

This manual is designed to provide you with the basic knowledge required to operate and maintain your HYTORC bolting equipment. Please read this manual carefully and follow the instructions provided. If you have any questions regarding HYTORC bolting equipment, please call us at 201-512-9500 or contact us at hytorsales@hytorc.com.

Your purchase of HYTORC bolting equipment entitles you to the following services at no extra cost to you.

Free on-site training in the application and operation of your HYTORC bolting equipment

- * Free semi-annual training
- * Free annual tool inspection.
- * Free loner tools in case of failure under warranty
- * Free engineering assistance by calling 1-800-FOR-HYTORC or our international office.

Your local HYTORC bolting specialist is available around the clock for your convenience. Should you require any assistance, please contact us to obtain our local specialist's information.

World-wide Warranty

HYTORC bolting equipment is engineered to the latest technological standards and is accompanied by our exclusive 12 word, 12-month warranty:

“YOU BREAK IT UNDER NORMAL USE, WE FIX IT FREE OF CHARGE!”

If your HYTORC equipment cannot be repaired on site, FREE loaner equipment will be made available to you upon request, while under warranty.

World-Wide

HYTORC®

Customer Service Policy

With the purchase of **HYTORC** Torque Machines, (past, present, future) you purchased the latest Technology and a **lifetime, world-wide Local Service:**

- ✓ FREE User-, Safety- Training upon Receipt of Merchandise
- ✓ FREE Semi- Annual User-, Safety- Training on Request
- ✓ FREE Annual Safety Seminar on Appointment
- ✓ FREE Loaner Tools in case of Product Failure Under Warranty
- ✓ FREE Torque/Tension Consultation/Seminar
- ✓ FREE Half Day, First Use Supervision
- ✓ FREE Annual Product Inspection on Request
- ✓ FREE Product Demonstration

(Above Services are NOT subject to travel expense charges)

REPAIRS:

- ✓ All repairs are guaranteed for 6 months
- ✓ Repairs are subject to labor and part cost, as outlined in official **HYTORC** Price List, dated January 1, 1999, enclosed
- ✓ All Warranty Repairs are FREE of all Charges, including return-freight. (HYTORC Warranty is 12 months, no questions asked.)
- ✓ All parts replaced with new ones will be returned to customer for inspection

TOOL RENTALS:

- ✓ 50% of all Rentals will be applied as a Discount toward New Purchases
- ✓ User Training for first time Rentals is FREE of all Cost
- ✓ Return freight charges are FREE
- ✓ Rental Tools are guaranteed to perform and are subject to the FREE Loaner Tool Policy of **HYTORC**

**Total Satisfaction Guaranteed or call
1-800-FOR-HYTORC**

All Payments are to be made to:

HYTORC®

Div. UNEX Corporation

333 Rte 17N, MAHWAH, NJ 07430, USA

Tel (201) 512-9500 Fax (201) 512-0530

www.hytorc.com

HYTORC® WORLDWIDE SERVICE



MAIN OFFICES WORLDWIDE

AFRICA

NORTH	HYTORC N. Africa & Middle East, Parc de Fontaine, Ave. Descazes 33200 Arques, France (33) 556 77 0000, HYTORC.ink@wanadoo.fr
SOUTH	HYTORC South Pacific, 6 Eton Road Keewick, 5035 South Australia Phone: 08 8293 8411, Fax: 08 8297 0648, Email: hytorc@coxmail.com.au

AMERICA

CENTRAL	HYTORC MEXICO, Av. Lazaro Cardenas 1902, Col. Man de la Piedra, C.P. 96416 Cuatrecasas, Ver. Mexico (52) 821-21-52790 Colsa@hytorc.com.mx
NORTH	HYTORC, Div. UNEX Corp, 333 Route 17N, Mahwah, NJ 07430 USA, (1) 201 512-9500, OASTURBNE@HYTORC.com
SOUTH	HYTORC Brasil, Rua Soares Avenue, number 45 - rooms 2507/2598, Centro - Rio de Janeiro - RJ - 20029-006 Brazil, 21 2229 2644, Fax: 21 2223 3154, Email: comercial@hytorc.com.br

ASIA

CENTRAL	HYTORC Shanghai, 1811 No. 2, 1046 Lane, Caoping Road, Shanghai, 200663 Republic of China 821 6254 8813, Fax: 821 6254 0894, Email: brucewei@hytorchina.com
EAST	HYTORC Japan, 3-42-6 Kojin Minami, Sugiyama-ku, Tokyo 165-0003 Japan 83 3314 3315, Fax: 03 3314 3671, Email: info@hytorc.co.jp
INDIA	HYTORC Mumbai, 395 Aarey Corner, Sector 17, Vashi, Near Mumbai 400703, India 022 258 11164, Fax: 022 258 11265, Email: hytorc@vsnl.com
SOUTH	HYTORC South Pacific, 6 Eton Road Keewick, 5035 South Australia 08 8293 8411, Fax: 08 8297 0648, Email: hytorc@coxmail.com.au

AUSTRALIA

AU. NZ.	HYTORC South Pacific, 6 Eton Road Keewick, 5035 South Australia 08 8293 8411, Fax: 08 8297 0648, Email: hytorc@coxmail.com.au
----------------	--

EUROPE

BENELUX	HYTORC Nederland, St. Janberg 15, NL 6862 KD Grootste Bloeidweg NL, (31) 24 306 0669, M.V.Katerina@HYTORC.NL
EAST	HYTORC Central Europe, Weisergasse 140, A-2300 Perchtoldsdorf, Austria, (43) 1-865-1368, EN@HYTORC.CentrEurope.com
GENERAL	HYTORC EUROPE, 2 avenue Mozart, 75016 Paris, France 31 42 89 47 45, Fax: 01 42 89 66 56, Email: info@hytorc.fr
GERMANY	Schönlank & Kip-Orbit, Justus-von-Liebig-Ring 17, Oberlegelbühl Km 2, D-42152 Hückling, Germany, 089 230 350 0, Fax: 089 230 350 11, Email: hytorc@toll.com
NORTH	HYTORC UK, Unit 24A, Spence Court, Elyth Industrial Estate, Elyth, Northumberland NE24 5TW United Kingdom, 01 673 383900, Fax: 01 673 383803, Email: sales@hytorc.co.uk
SCANDINAVIA	HYTORC Norge, Sandvika 14 4190 Sikk, NORWAY, (47) 51 713-400 Kundenervice@HYTORC.NO

Call **1 800 FOR HYTORC**
367-4986

HYTORC®

Division of UNEX Corporation
333 Route 17 North, Mahwah, NJ 07430 USA
Tel: 1 201 512-9500, Fax: 1 201 512-9615
E-Mail: HYTORCdisc@HYTORC.com
www.HYTORC.com

5699HYT0604

Copyright 2004 © HYTORC,
Division of UNEX Corporation

INTRODUCTION

HYTORC tools are uniquely multi-purpose. They can be used as accurate bolting equipment on conventional nuts in open or confined spaces. They also can be used as reaction arm free tensioning equipments, when used with HYTORC LoadISC washer or HYTORC-Clamp, Hydraulically Actuated Mechanical Tensioner.

SECTION I

IMPORTANT SAFETY INSTRUCTIONS

HYTORC tools are designed for the safety of operators. However, they are powerful tools and certain safety precautions should be observed to avoid accidents or personal injury. The following tips will assist you.

READ ALL INSTRUCTIONS

KEEP WORK AREA CLEAN AND WELL LIT

CONSIDER WORK AREA ENVIRONMENT

Electric pumps should never be used in any atmosphere which can be considered potentially volatile. If there is any doubt, use an air pump.

Also note: Metal to metal contact can cause sparks. Precautions must be taken.

AVOID PREMATURE TOOL STARTING

The pump remote control should be operated by a designated operator and ensure “ALL CLEAR” prior to starting and to avoid premature tool starting.

STAY CLEAR DURING OPERATION

In most cases, the tool will allow “hands free” operation. If the tool must be reset on bolt during operation, make sure the remote control operator is aware of turning the pump off.

IMPORTANT NOTE: NEVER HOLD THE TOOL DURING OPERATION!

GUARD AGAINST ELECTRIC SHOCK

Ensure the pump is properly grounded and the proper voltage is used.

STORE EQUIPMENT PROPERLY

When not in use, tools and accessories should be properly stored to avoid deterioration.

USE THE RIGHT TOOL

***refer to our recommended torque/load chart**

Do use tools or attachments suitable for the applications.

PROPER SAFETY ATTIRE

When handling/operating hydraulic equipment, wear work gloves, hard hats, safety shoes, safety glasses and other applicable clothing.

MOVING EQUIPMENT

Do not use hydraulic hoses, uniswivels, pump power or remote cords as means of moving the equipment.

SECTION I

IMPORTANT SAFETY INSTRUCTIONS -continued from the previous page-

HOSES

Do not kink hoses. Inspect and replace if damaged.

SHROUDS AND COVER PLATES

All tools are equipped with shrouds and/or cover plates to prevent contact with the moving internal parts. Do not use tools without these safety covers. If the covers are missing or damaged, replace immediately.

MAINTAIN TOOLS

For the best results, inspect tools, power packs, hoses, connectors, electric lines and accessories for visual damage before each usage. Always follow instructions for proper tool and pump maintenance.

SAFETY ALERT

Do not use power equipment under the influence of any mood altering substance.

PRIOR TO OPERATION

Ensure that all hydraulic connectors are securely connected. Verify that the hydraulic hoses are not kinked. Insure the square drive and its retainer are fully and securely engaged.

PRIOR TO USE (if use with reaction arm)

Before placing your tool on the application, cycle it to ensure proper function. If using the torque mode, locate a solid and secure reacting point. Be sure the reaction arm is retained firmly and positioned to face the same direction as the square drive. Be sure the hydraulic hoses are free of the reacting point. Pressurize the system momentarily; if the tool tends to “ride up” or to “creep”, stop and adjust the reaction arm to a solid and secure position.

NOTE: Remain clear of the reaction arm during operation and never put body parts between reaction arm and reaction surface.

ALWAYS USE QUALITY ACCESSORIES

Use genuine HYTORC accessories. Use correct size accessories and engage them fully. Stay clear of all moving accessories during operation.

DO NOT USE FORCE

Do not apply any impact by using hard objects on bolting equipment or accessories. This may cause malfunction or breakage.

ALWAYS CONSULT

Please contact HYTORC for any questions related to our equipment or your bolting needs. Safety is always the number one priority.

SECTION II

INSTRUCTIONS BEFORE USING YOUR NEW HYTORC

READ CAREFULLY: Most malfunctions, in new equipment, are the result of improper operation and/or set-up.

PREPARATION: Remove HYTORC equipment from shipping container.

INSPECTION: Visually inspect all components for any damage during transportation. If damages are found, notify HYTORC immediately.

2-1 Working Pressure The tool's maximum working pressure is 10,000 PSI (700kg/cm², 690 Bar) Make sure that all hydraulic equipment used is rated for 10,000 PSI operating pressure. To set pump pressure for XXI models to 10,000 PSI for both advance & retract, locate selector valve underneath the couplers. Turn the pump off and loosen the lock nut. Turn the center screw counter-clockwise until it stops. Tighten the lock-nut. For Avanti & Stealth models, turn the center screw clockwise until it stops. Tighten the lock-nut to set the pump pressure to 1,500 PSI for retract.

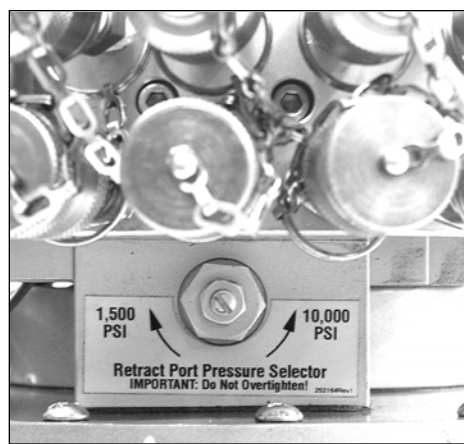

2-2 Hydraulic Connections With older style pumps, (SST-10, SST-20), the retract side of the system may remain pressurized after the pump has been switched "off". This trapped pressure makes it impossible to loosen the retract-side fittings by hand. To release the pressure, find the 5/16 manual override holes in the end of the black solenoids on the pump. With a welding rod, Allen-key or similar device, push in on the ends of both solenoids, each in turn, and the residual pressure will be released. All fittings will, then, be hand tightened again. Hoses and couplers must be free and unobstructed before and during the operation of the tool. External impact on the couplers may break off the fittings.

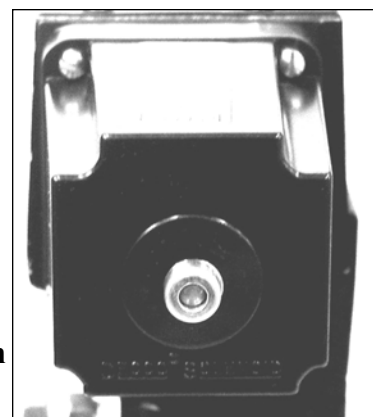

Current pump models are equipped with an auto-pressure relief. Never disconnect or connect any hydraulic hoses or fittings without first unloading wrench and the pump. Double check the gauge reading to assure pressure has been released.

When making connections with quick disconnect couplings, make sure the couplings are fully engaged. Threaded connections such as fittings and gauges must be clean and securely tightened and leak free.

CAUTION: Loose or improper threaded fittings can be potentially dangerous if pressurized. Severe over tightening can cause premature thread failure. Never grab, touch or in any way come in contact with a hydraulic pressure leak. Escaping oil can penetrate the skin and cause injury.

SECTION II

INSTRUCTIONS BEFORE USING YOUR NEW HYTORC -continued from the previous page-

2-3 ELECTRICAL CONNECTIONS Ensure proper power availability to prevent motor failure or dangerous electrical overloading. Compare the motor nameplate for required amperage. Do not use electric pump, if three prong electrical plug is not whole. Minimize the length of extension cords and be sure they are of adequate wire size, with ground connectors. Extension cord up to 50 feet should be #10 AWG gauge.

CAUTION: Electric motors may spark. Do not operate in an explosive atmosphere or in the presence of conductive liquids. Use an air pump instead.

2-4 AIR CONNECTIONS Ensure that you have sufficient air flow of 80 psi (50 cfm) to operate your pneumatic pump. If in doubt, compare the pump manufacturer's recommended air flow rating prior to pressurizing pump. Improper air flow may damage the pump motor. For best results, use air hose larger than 3/4 " diameter.

Use of a filter regulator lubricator (FRL) is highly recommended. (diagram below)

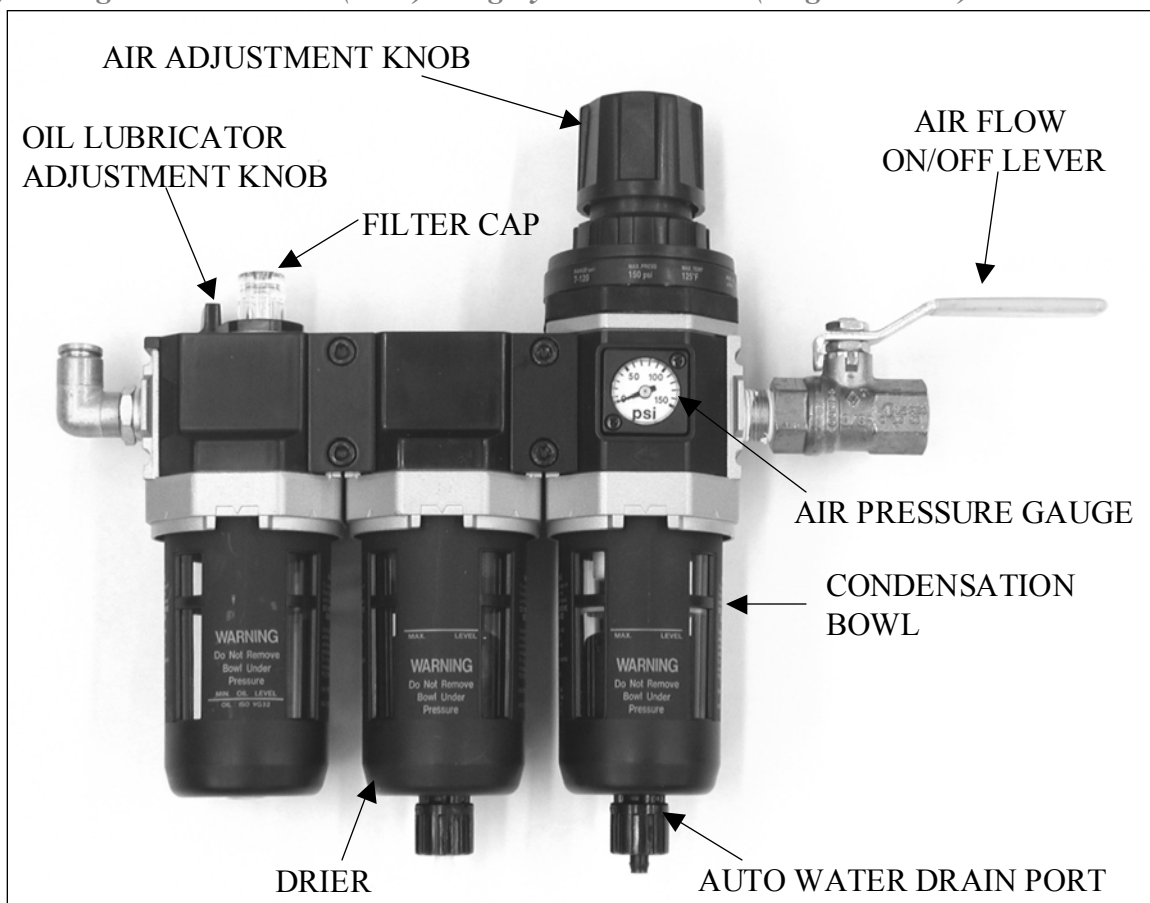

1. Adjust flow to 1-2 drops per minute.
2. Fill half way with grade 46 hydraulic oil supplied.

SECTION III

OPERATION – Torquing Conventional Nuts

3-1 General All HYTORC tools are supplied completely assembled and are ready to use. A HYTORC Hydraulic Power Pack, for use with your HYTORC tools, is recommended to provide the speed, pressure and portability that makes your HYTORC SYSTEM more efficient and accurate.

The SYSTEM accuracy of your HYTORC tool is $\pm 3\%$ based upon manufacturer's specifications. This accuracy may be certified through calibration by HYTORC or any other qualified calibration facility whose program is traceable to the National Institute of Standards and Technology (N.I.S.T.) Using a calibrated gauge enhances the accuracy of your HYTORC SYSTEM.

3-2 Connecting the SYSTEM

The wrench head and power pack are connected by a 10,000 PSI operating pressure (40,000 PSI burst) twin line hose assembly. Each end of the hose have one male and one female connector to assure proper interconnection between pump and wrench head.

IMPORTANT: To avoid tool malfunction, do not reverse connectors.

Connect the twin line hose to the uniswivel as shown below. Make sure male couplers are connected to female couplers. During the operation, check the connection to ensure the couplers are not loose. Insure the connectors are fully engaged and screwed snugly and completely together.

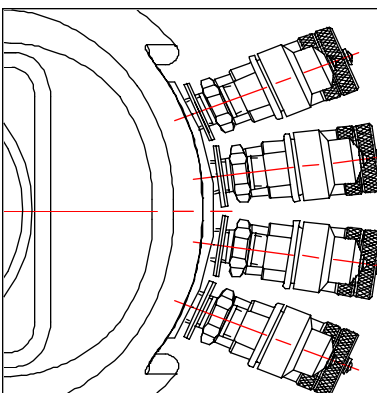
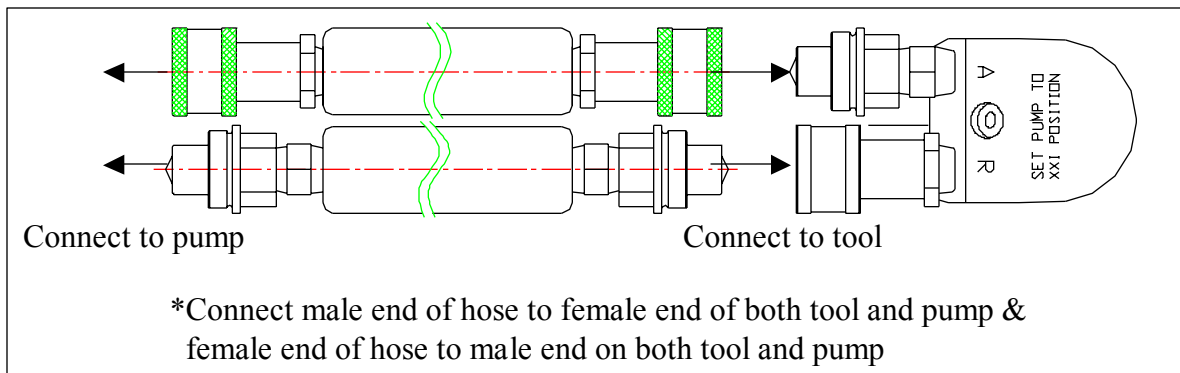

From hose

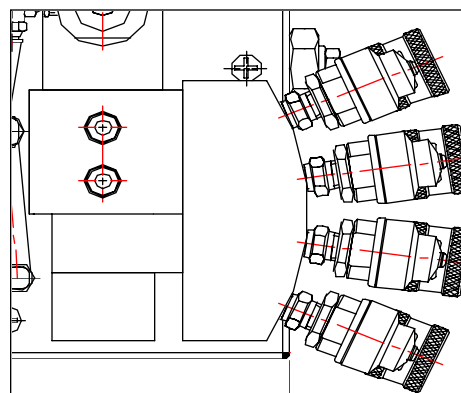

From hose

SECTION III

OPERATION – Torquing Conventional Nuts -continued from the previous page-

3-3 Drive Direction Change

Avanti tools To remove the square drive, disengage the drive retainer assembly by depressing the retaining round button and gently pulling on the square end of the square drive. The square drive will slide out. To insert the drive in the tool, place the drive in the desired direction, engage drive spline and ratchet spline, then twist bushing until engage to the housing spline. Push drive through ratchet. Depress drive retainer button, engage retainer with drive and release button to lock.

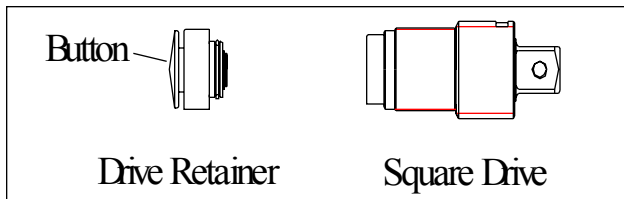

The diagram on the right illustrates the direction that the square drive should face for tightening and loosening of a standard right hand fastener.

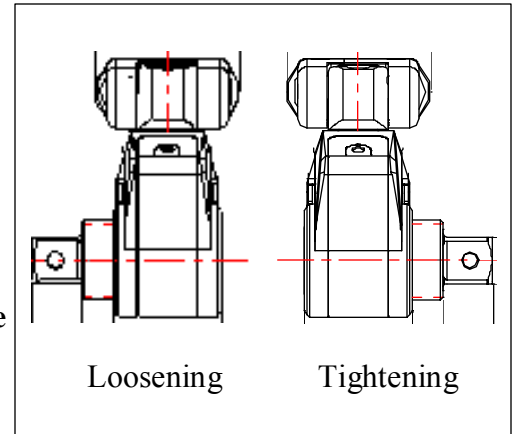

Stealth tools The Stealth tools use interchangeable ratcheting links. For tightening, simply engage the nut with the right side of the link facing down. For loosening, the left side of the link faces down. Ratcheting link can be detached from the Stealth power head by pulling the power head out while pressing the button shown below.

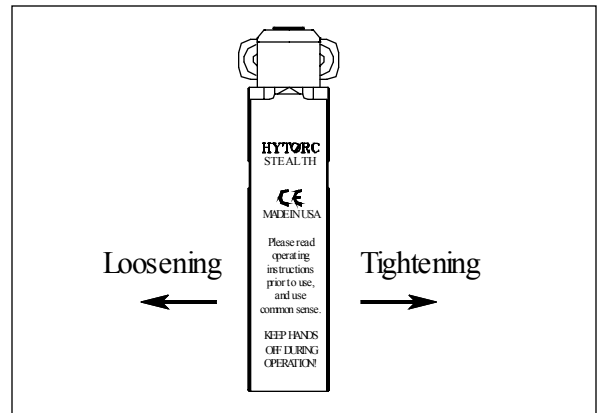
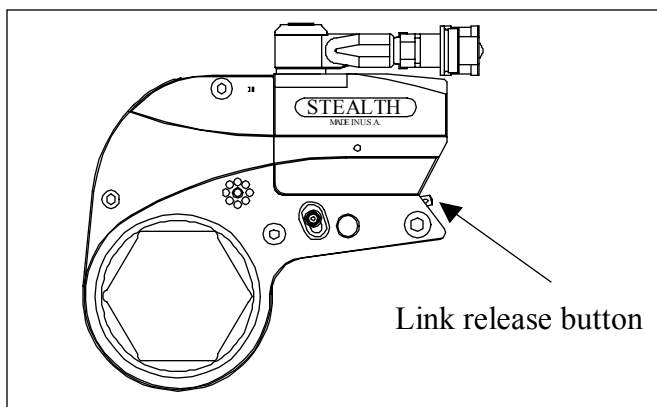

3-4 Reaction Arm The Avanti can be used with a 360 degree adjustable universal reaction arm.

Make sure the reaction arm spline is fully engaged on the square drive spline. Secure the position by tightening the set screw on the reaction arm.

***ALWAYS USE A SAFETY HANDLE**

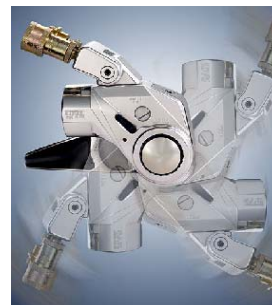

SECTION III

OPERATION – Torquing Conventional Nuts -continued from the previous page-

3-5 Setting Torque

Once the SYSTEM is fully connected and the proper power supply is available, it is time to adjust the pump pressure to the level needed on your job. When tightening, use the manufacturer’s specifications to determine the torque value ultimately required. Appendix I – which is presented as a guideline for comparison only – gives typical torque values specified for the most commonly encountered fasteners. Torque sequence varies from plant to plant and even within the same plant may vary depending on the gasket material and other factors. Always abide by on-site-procedures.

Always refer to the pressure-torque conversion table that came with the tool.

3-6 Setting the Pressure on the Pump

To set the pressure on the pump, follow this procedure.

1. Loosen the knurled locking ring below the “T” handle on the pump’s external pressure regulator. Then turn the “T” handle counter-clockwise until it turns freely and easily.
2. Turn the pump “ON”. Using the pump’s remote control pendant, push down the advance switch (or button on air pump) and hold it.
3. While holding the pump in the advance mode, slowly turn the “T” handle clockwise and observe the pump pressure gauge rise.

NOTE: Always adjust the regulator pressure up – never down.

4. Once the desired pressure is reached. Turn off the pump and “LOCK IN” the pressure by tightening the knurled lock nut. Turn on the pump once more and pressurize to verify the pressure is maintained.



3-7 Applying the Avanti – the Tightening Process

1. Once your target pressure is set, cycle the tool three or four times to full pressure. Cycling the tool ensures that the system is operating properly and removes trapped air, if any.
2. Place the proper size driving unit on the square drive and secure properly.
3. Place the tool on the bolt, making sure that everything is fully engaged. Further ensure that the drive retainer is engaged.
4. Make sure the reaction arm is firmly abutted against a stationary object.
5. When positioning the wrench, make sure that the hose connections are well clear of any obstructions.
6. After all the above are confirmed, apply momentary pressure to the SYSTEM to ensure proper tool placement.

SECTION III

OPERATION – Torquing Conventional Nuts -continued from the previous page-

3-7 Applying the Stealth – the Tightening Process

1. Once the target pressure is set (refer to 3-6) Cycle the tool several times to full pressure to assure proper operation.
2. Place the right side of the ratchet link directly over the nut. Ensuring the hex is fully engaged and the reaction pad portion of the link abuts solidly against an adjacent nut or other stationary object. (see 3-3 for proper tool placement)
3. Ensure hose connections are clear of any obstacles.
4. After all the above are confirmed, apply momentary pressure to the SYSTEM to assure the reaction point is stable.

3-8 Operating the Avanti and Stealth SYSTEMS

1. By pushing down on the remote control button in the advance position, the rear of the tool will be pushed back until the reaction surface will contact its reaction point.
2. Continue to hold down the advance button as the socket turns until you hear a “CLICK” which will signify the hydraulic cylinder inside the tool is fully extended and will not turn the socket further.
3. Continuing to hold down the remote control button will result in a rapid buildup of pressure to the point of where the gauge reads what was preset prior to applying the wrench.

IMPORTANT: The reading of full preset pressure after the cylinder is extended DOES NOT INDICATE that this pressure (torque) is applied to the bolt. It only indicates that the cylinder is fully extended and cannot turn the nut further until the tool automatically resets itself.

Releasing the remote control button will retract the cylinder. The tool will automatically reset itself and the operator will hear a “CLICK” indicating he can again push the remote control button and the socket will turn. Each time the cylinder is extended and retracted, it is called a cycle. Successive cycles are made until the tool “STALLS” at the preset Torque/PSI with an accuracy of +3%. Repeatability is +-1%.

IMPORTANT: ALWAYS ATTEMPT ONE FINAL CYCLE TO INSURE THE “STALL” POINT HAS BEEN REACHED.

NEVER HOLD THE TOOL DURING OPERATION.

Use safety handle to set and remove tools.

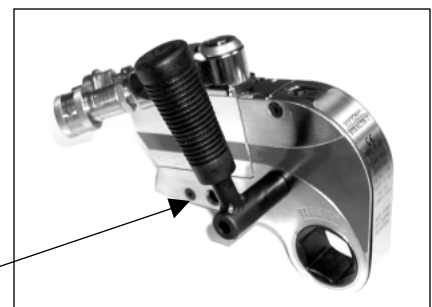

SECTION III

OPERATION – Torquing Conventional Nuts -continued from the previous page-

3-8 Operating the Avanti and Stealth SYSTEMS

Releasing “LOCKED-ON” tools.

Should the tool “LOCK-ON” after the final cycle, slide the slider (or the lever on Avanti) with the pump off or in retract position. Turn the pump back on and while maintaining the pressure, cycle Avanti in the pump’s manual mode. Should Stealth “LOCK-ON”, advance pump pressure and while advancing, press down on the release button located on the sides of the ratchet link. Once you are able to press down the button without resistance, continue holding the button down and release the advance pressure on the pump. Shut off the pump, and remove the tool from the nut.

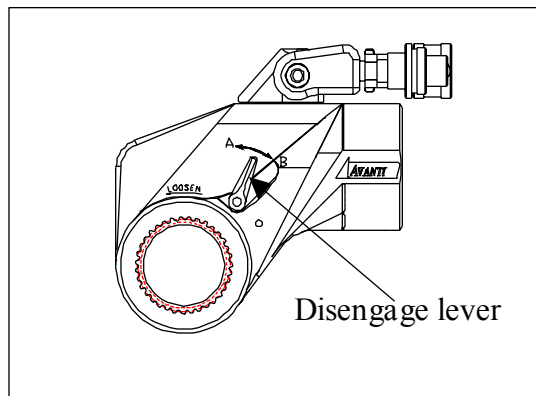

Avanti Release Procedure

- 1) Push lever to position A
- 2) Cycle tool in manual mode, release advance button
- 3) Shut pump off
- 4) Remove tool and reset lever to position B

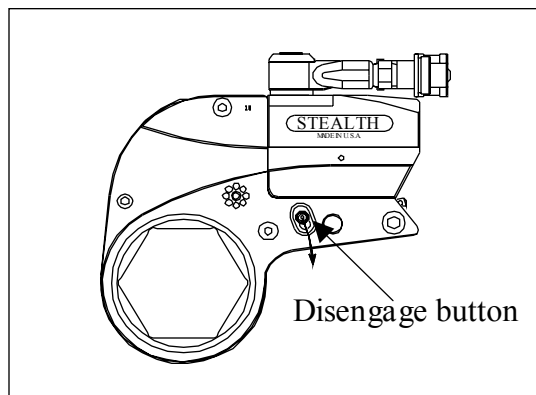

Stealth Release Procedure

- 1) Push remote to full pressure for final stroke
- 2) Disengage the reaction pawl by holding the button in the direction of arrow
- 3) Release the rocker switch
- 4) Shut pump off
- 5) Remove tool

SECTION III

OPERATION – Torquing Conventional Nuts -continued from the previous page-

3-9 Loosening Procedures Avanti and Stealth SYSTEM

First, set the pump to 10,000PSI. Set the tools for the loosening mode (Refer to 3-3), assuring the reaction surface abuts squarely off a solid reaction point. Press and hold the remote control button down. Pressure will decrease as the socket begins to turn. As the cylinder extends fully, you will hear a “CLICK”. Release the remote control button and the cylinder automatically retracts, at which time you again hear a “CLICK”. Repeat this process until the fastener can be removed by hand.

NOTE: If the bolt does not loosen with the above procedure, it is an indication that you may require the next larger size tool to loosen the bolt. Corroded nuts and thread galling on bolts can cause difficulty in loosening. Please consult your HYTORC bolt specialist.



SECTION IV
OPERATION – HYTORC LoaDISC and Clamp

4-1 Tool Set up and Operation

When used in conjunction with the HYTORC LoaDISC Washer or Clamp, the operation is essentially the same as with the conventional nuts, but with one notable exception: **THERE ARE NO REACTION FORCES TO CONSIDER OR PROVIDE FOR!** The reaction forces are absorbed through the fastener assembly itself. Each individual customer order for LoaDISC or Clamps will be provided with specific installation instructions for each application. However, the following general guidelines outline correct installation procedures.

4-2 HYTORC LoaDISC Tensioning

1. Do not use grease or lubricants on LoaDISC , nut, bolt or joint face. LoaDISC is “DRY LUBE” protected.
2. Place the LoaDISC over the bolt with the flat surface firmly against joint face.
3. Install the nuts on the bolt and hand tighten snugly on both sides of assembly.
4. Set required pump pressure.
5. Place tooling to engage a nut and the LoaDISC with “TIGHTENING” side facing the operator.

-continued to the next page-

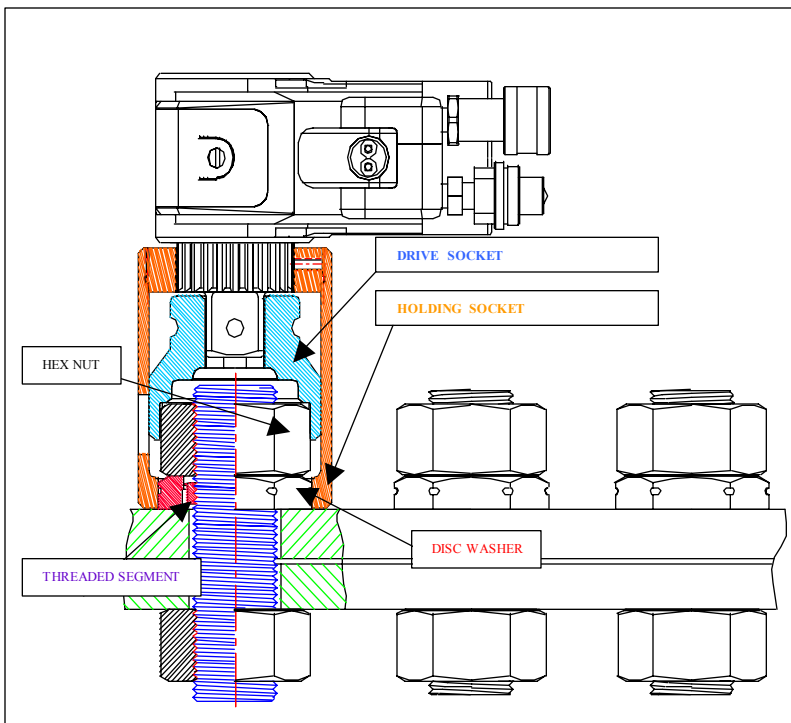

Soft Joint LoaDISC



Reusable LoaDISC



Hard Joint LoaDISC



**Limited Clearance
LoaDISC**

SECTION IV

OPERATION – HYTORC LoadISC and Clamp -continued from the previous page-

4-2 HYTORC LoadISC Tensioning

6. Verify proper socket engagement by momentarily pressurizing tool. If tool remains stationary, operate normally until tool “STALLS OUT”

7. Should tool rotate during initial pressurizing:

A. Insure both socket and sleeve are fully engaged.

B. Insure that joint faces are free from grease and oil.

*Also refer to the trouble shooting section (4-4)

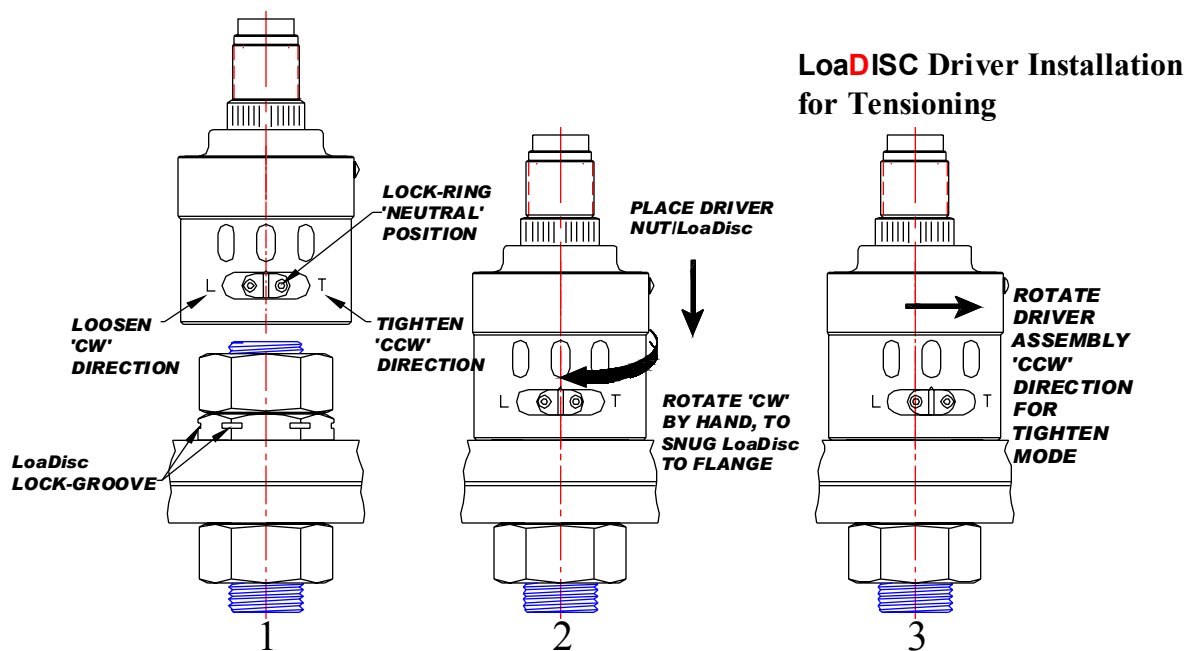

NOTE:

- * DO NOT GRAB A SWIVEL DURING OPERATION!
- * DO NOT PLACE TOOL HOUSING TO ABUT AGAINST STATIONARY OBJECTS
- * DO NOT STAND UNDERNEATH OR CLOSE TO TOOL
- * DO NOT RE-USE SINGLE-TIME USE LoadISC

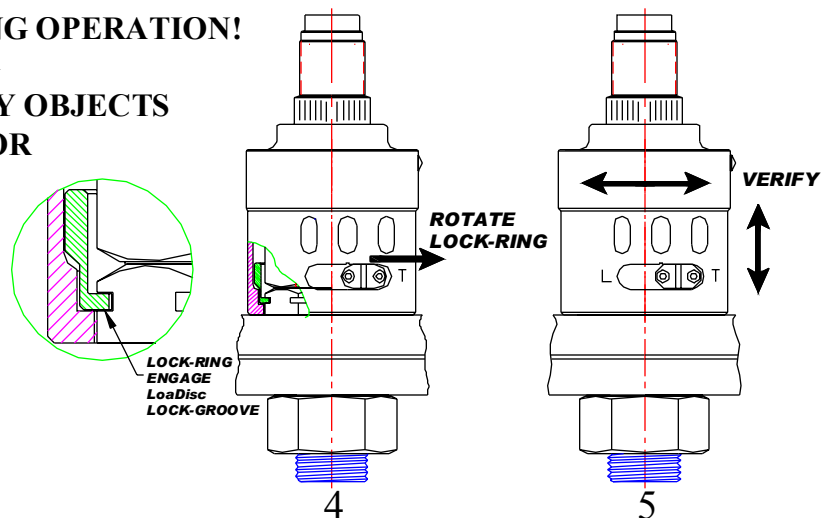

SECTION IV

OPERATION – HYTORC LoaDISC and Clamp -continued from the previous page-

4-3 HYTORC LoaDISC De-tensioning

1. Set pump to maximum pressure.
2. Place tooling to disengage the nut and the LoaDISC with “LOOSENING” side facing the operator.
3. Verify proper socket engagement by momentarily pressurizing tool. If tool remains stationary, operate normally until the nut is loose.
4. Should tool rotate during initial pressurizing:
 - A. Insure both socket and sleeve are fully engaged.
 - B. Insure that joint faces are free from grease and oil.

*Also refer to the trouble shooting section (4-4)

LoaDISC Driver Installation for De-tensioning

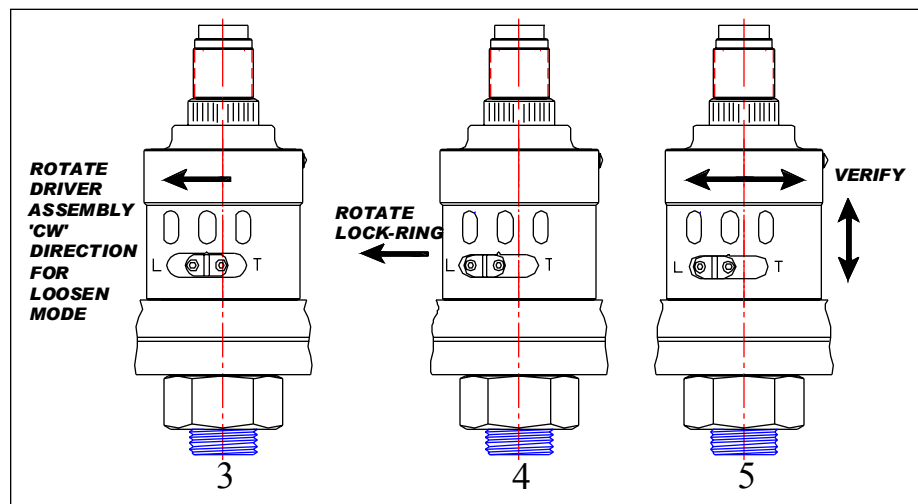

Releasing “LOCKED-ON” tools. (Refer to 3-8 for Avanti and Stealth)

Should the tool “LOCK-ON” after the final cycle, slide the slider with the pump off or in retract position. Turn the pump back on and while maintaining the pressure, cycle XXI in the pump’s manual mode. the pump. Shut off the pump, and remove the tool from the nut.

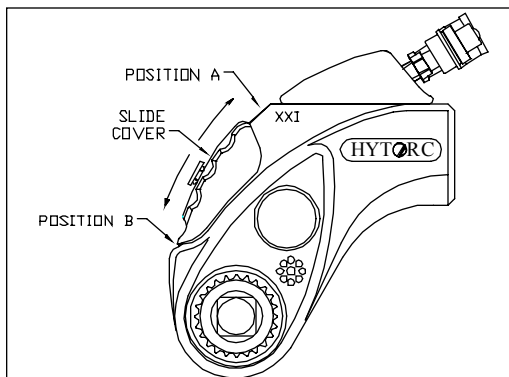

XXI Release Procedure

- 1) Push slide cover up to position A
- 2) Cycle tool in manual mode, release advance button
- 3) Shut pump off
- 4) Remove tool and reset slide cover to position B

SECTION IV

OPERATION – HYTORC LoadISC and Clamp -continued from the previous page-

4-4 HYTORC LoadISC Lubrication Instruction & Trouble Shooting

- STEP 1:** Make sure all threads and surfaces are free of dirt or grit.
- STEP 2:** Apply spray lube TS801 moly spray to nut per procedure indicated below. Allow spray lube to dry (spray lube is shipped with LoadISC order). Refer to the Dry-lube container label for a drying time. **Do Not Apply Lube to LoadISC**
- STEP 3:** Clean and dry protruding stud threads and nut seat surfaces.
- STEP 4:** Install LoadISC with flat side against joint, turn till snug.
- STEP 5:** Install lubricated hex nut on top of LoadISC , snug against top surface of LoadISC .

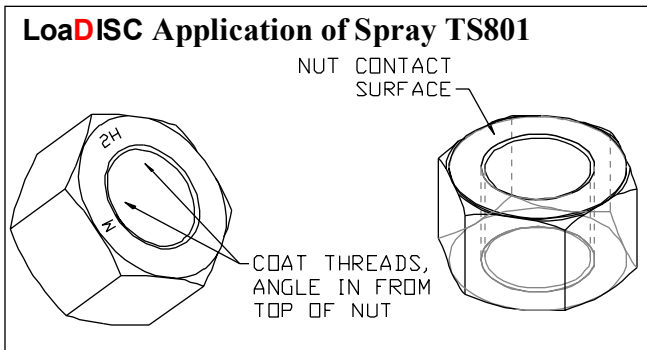

NOTE:

- *Allow sufficient time for spray to dry before use.
- Hex nut can be reused, if re-lubricated per illustration.

NO NOT REUSE ONE TIME USE LoadISC

HYTORC LoadISC Trouble Shooting

SYMPTOM	CAUSE	SOLUTION
Driver does not lock	Lock ring misaligned with LoadISC	Check for excessive stud protrusion Check that holding socket is flush to flange surface
	LoadISC groove damaged	Replace LoadISC
	Missing or damage lock-ring	Replace lock-ring
	LoadISC not snug against flange surface	Tighten LoadISC to flange surface with driver assembly (CW direction)
Driver un-locks during verification	Worn lock-ring	Replace lock-ring
Driver un-locks during use	Lock-ring rotated in wrong direction	Rotate Holding socket and lock-ring •CCW toward 'T' for Tighten •CW toward 'L' for Loosen
Driver does not un-lock after torque procedure	Stud driven up into bottom of drive socket	Check for excessive stud extension.

SECTION IV

OPERATION – HYTORC LoadISC and Clamp -continued from the previous page-

4-5 HYTORC Clamp Installation - Tensioning

The HYTORC Clamp is provided with lubrication and is shipped ready for use. For re-lubrication, please refer to lubrication Instructions. (4-6)

- 1. Thread the Clamp down on the stud, turn the Puller Sleeve to contact the flange, contacting the flange or the spot face firmly. The Clamp should fit easily onto the spot face.**
 - 2. The Puller Sleeve, when properly installed, should protrude no more than 1/16 (15mm) past the top of the Nut (outside sleeve). If the Puller Sleeve is raised beyond 1/16", hold the Puller Sleeve or the Bridge by hand and turn the Nut counter-clockwise (loosen direction) until the Puller Sleeve protrudes no more than 1/16" past the top of the Nut. After adjusting the Nut, turn the entire Clamp assembly down to contact the flange or the spot face firmly.**
 - 3. Before using XXI tool on the Clamp, make sure the tool and the drive member are set properly. The castellated drive and the splined reaction member should stick out on the right side for tensioning. Cycle the tool and the drive a few times to ensure that the tool is properly operating. Repeat this step only when you change the tool or the drive.**
 - 4. Refer to the load chart supplied with the Clamp and set the pump pressure to achieve the desired load. Do not engage drive on the Clamp while setting the pump pressure. Turn the pressure regulator counter-clockwise to set it below the target pressure. While holding the advanced button on the remote control, slowly turn the pressure regulator clock wise to increase the pressure to the desired value. Ensure the pressure value is set properly by holding the advanced button.**
 - 5 Before applying the tool and the drive, engage the splined reaction member to the Puller Sleeve first. Then engage the castellated drive to the castellated section of the Nut. Turn the drive manually until both castellations are fully engaged.**
- IMPORTANT:** If the castellated teeth do not fully engage, the Puller Sleeve is sticking up too far or stud protrusion is more than maximum value. Refer back to Step 3. Then reposition the Puller Sleeve and check stud protrusion.
- 6 Apply the pump pressure to tension the Clamp, until the target pressure is reached. To ensure that the proper tension has been applied to the stud, allow the tool to fully retract then advance to the target pressure a final time.**
 - 7 Repeat 5 & 6 until all bolts are fully tensioned.**

SECTION IV

OPERATION – HYTORC LoadISC and Clamp -continued from the previous page-

4-6 HYTORC Clamp Installation - Detensioning

1. Before using XXI or Avanti tool on the Clamp, make sure the tool and the drive member are set properly. The castellated drive and the splined reaction member should stick out on the left side for detensioning. Cycle the tool and the drive a few times to ensure that the tool is properly operating. Repeat this step only when you change the tool or the drive.
2. Detensioning, in general, requires higher pump pressure. Refer to the load chart and set the pump pressure slightly higher than the value used for tensioning. Turn the pressure regulator counter clockwise to set it below the target pressure. While holding the advanced button on the remote control, slowly turn the pressure regulator clockwise to increase the pressure to the desired value. Ensure the pressure value is set properly by holding the advanced button.
3. Remove drive from tool, engage the splined reaction member to the Puller Sleeve first. Then engage the castellated drive to the castellated section of the Nut. Turn the drive manually until both castellations are fully engaged. Place tool on drive with “LOOSEN” side facing the operator. Install drive retainer.
4. Apply the pump pressure to detension the Clamp, until it can be turned by hand.
5. Repeat 3 & 4 until all bolts are fully tensioned. On applications that require two or three passes to tension, it is advised to detension the last few bolts in two passes.

If corrosion makes it impossible for the Clamp to be turned by hand even after detensioning, use the hex/spine adaptor. To use the hex/spine adaptor, insert the male spline of the adaptor into the female spline of the Puller Sleeve. Place a wrench over the hex of the adaptor and rotate the Sleeve off the bolt.

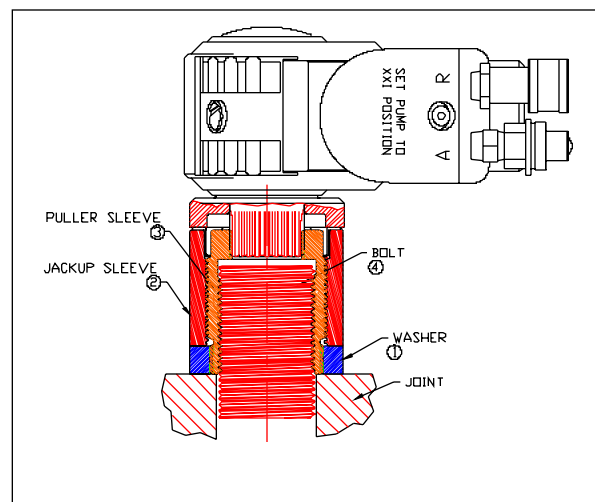

NOTE: Before reusing the Clamps, it is imperative that the Clamps are properly cleaned and re lubricated to prolong their life. Refer to the lubrication instruction on the next page.

SECTION IV

OPERATION – HYTORC LoadISC and Clamp -continued from the previous page-

4-7 HYTORC Clamp Lubrication Instruction

The Clamp Lubrication Instructions: (Use a clean stiff bristle brush)

- STEP 1:** Make sure all threads and splines are free of dirt or grit. Generously grease internal threads on the Jack-up Sleeve with a brush to get full coverage to the thread root.
- STEP 2:** Generously grease external threads on the Puller Sleeve with a brush to get full coverage to the thread root.
- STEP 3:** Grip the bottom splined section and internal threads of the Jack-up Sleeve into the Jack-up Sleeve as the arrow indicates. Leave the bottom splined section sticking out the bottom.
- STEP 4:** Turn the assembled parts upside-down. Spread excess grease around to coat bottom surface of the Jack-up Sleeve and splines. Apply grease on the splines if coating is thin.
- STEP 5:** Apply grease to internal splines on the Washer to get full coverage to the spline root. Coat top surface of the Washer.
- STEP 6:** Slide the Washer to the assembled Sleeves as the arrow indicates. When the Puller Sleeve and the Washer are in contact, the Puller Sleeve and the Washer bottoms should be flush with each other. Rotate the Jack-up Sleeve while holding the Washer to achieve this desired condition.

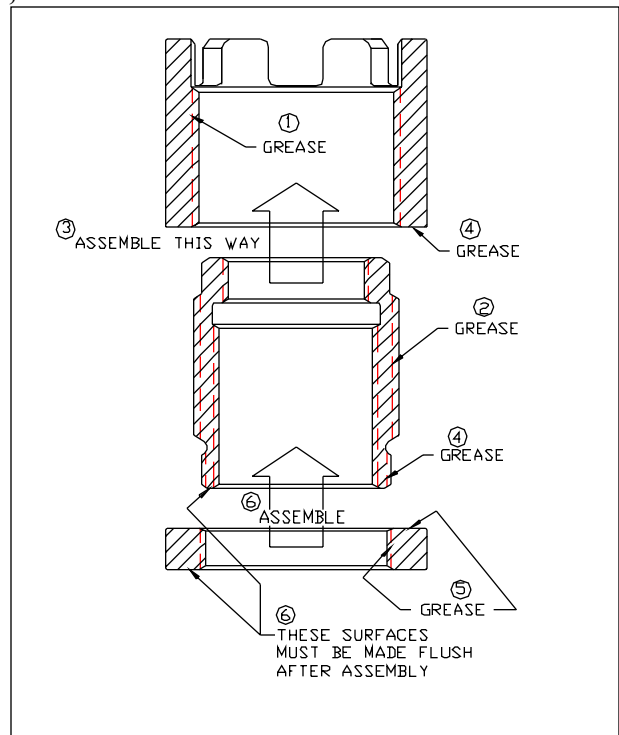

SECTION V
OPERATION – HYTORC Power Packs

5-1 HYOTRC Power Packs General Information

All HYTORC Power Packs operate at a pressure range from 500 to 10,000 PSI and are fully adjustable. They have been engineered and designed for portability and high flow for increased speed. Before using your HYTORC Power Pack, check the following points:

- Is the reservoir filled with oil?
- Where is the closest electrical outlet at the job site? (Electric pump only)
- Is there enough air pressure (100 PSI) and flow (50 CFM) at the job site? (Air units only)
- Is the gauge mounted and rated for 10,000 PSI
- Is the oil filler plug securely in place?

The Power Packs maximum working pressure is 10,000 PSI (700 kg/cm², 690 Bar) Make sure all hydraulic equipment and accessories are rated for 10,000 PSI operating pressure.

5-2 Hydraulic Connections

When making a connection with quick connect couplings, make sure the couplings are fully engaged. Threaded connectors such as fittings, gauges etc. must be clean and securely tightened and leak free.

CAUTION: Loose or improperly threaded couplers can be potentially dangerous if pressurized. Severe over tightening can cause premature thread failure. Knurled sleeve on couplers need to be only hand tight. Never grab, touch or in any way come in contact with a hydraulic pressure leak. Escaping oil can penetrate the skin and cause injury. Do not subject the hose to potential hazard such as sharp surfaces, extreme heat or heavy impact. Do not allow the hose to kink and twist. Inspect the hose for wear before each usage.

5-3 Prior to Use

Do not use a power or extension cord that is damaged or has exposed wiring. All single phase motors come equipped with a three prong grounding type plug to fit the proper grounded type electrical outlet. Do not use a two prong ungrounded extension cord as the pump’s grounded type electrical outlet. Compare motor nameplate against power availability to prevent motor burnout or dangerous electrical overloading.

*For electric cord extension, refer to below chart

0-25 Foot Extension	Use size 12 gauge cord
26-50 Foot Extension	Use size 10 gauge cord
51-75 Foot Extension	Use size 8 gauge cord
76-100 Foot Extension	Use size 6 gauge cord

Check hydraulic oil level to prevent possible pump burnout. Look at oil fill level on the oil sight gauge. The oil level should be approximately 2” from the top of the reservoir plate-with motor off. Add HYTORC oil as necessary.

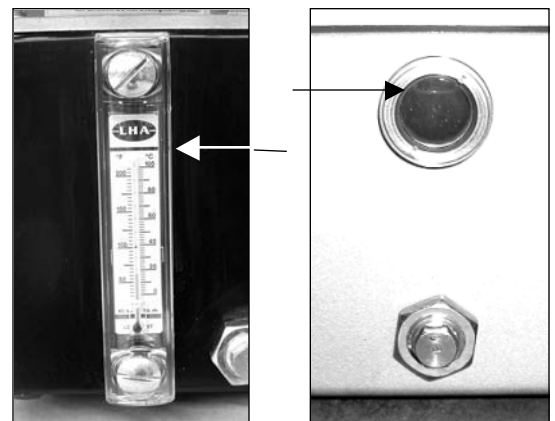

Air Pump Oil Sight Gauge

Electric Pump Oil Sight Gauge

*Do not mix different grades of oil.

SECTION V

OPERATION – HYTORC Power Packs -continued from the previous page-

5-3 Prior to Use -Continued-

Make sure all desired gauge, valve, hose and quick coupler connections are tight and secure. The gauge permits the operator to monitor the load on the wrench.

*Calibrated gauges are available for most application.

Before starting your HYTORC pump, connect your hydraulic hoses to both the pump and torque wrench. (Refer to 3-2)

5-4 Operation Electric Pump

Push the rocker switch on the hand control pendant in the OFF position. Then, depress and release the safety button.

NOTE: The safety button is an added feature designed to prevent premature starting and should only be depressed by the tool operator.

Push the rocker switch to advance position and release it. This will start your pump and place it in the retract position. Your HYTORC electric pump has been designed with an auto shut off system. The pump will shut off after approximately 20 seconds of non-cycling. This will prevent overheating or unnecessary wear and results in longer life of your pump. To restart the pump, depress the safety button again.

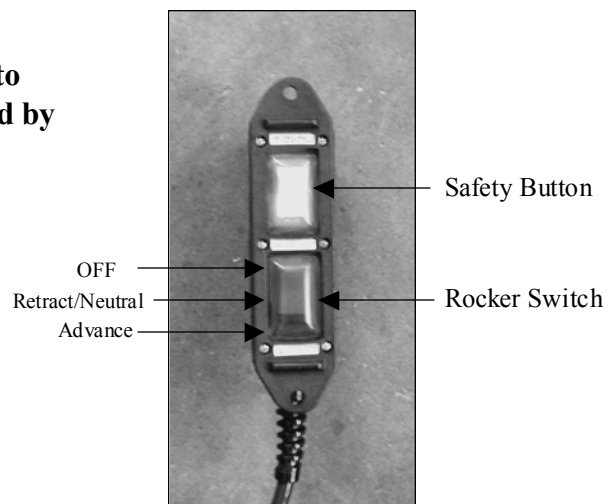

5-5 Operation Air Pump

Before connecting air supply line to the Air Filter Lubricator, make sure the Air Flow Lever is in the OFF position. Then connect air supply line. Open the Air Flow Lever. Check the PSI reading on the Air Pressure Gauge. It should be at 100 psi. Depress the Air Adjustment Knob to increase psi reading. Adjust lubricator to approximately one drop per Minute.

*Before operating your HYTORC air pump, check for air leaks on the air hoses/tubing.

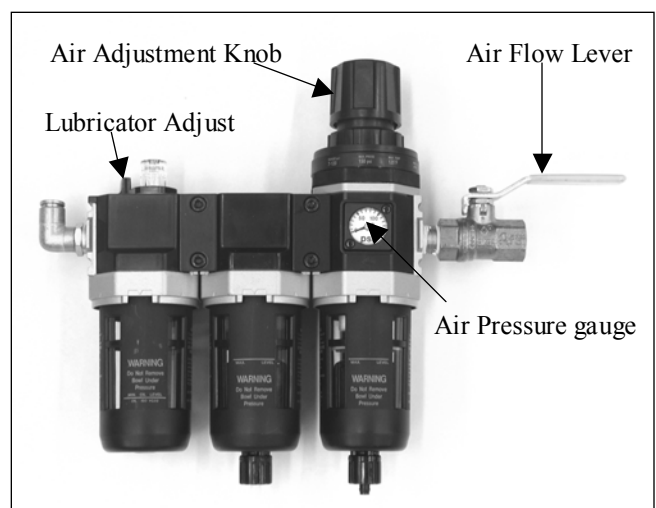

SECTION V

OPERATION – HYTORC Power Packs -continued from the previous page-

5-5 Operation Air Pump

To start the pump, depress the advance button and release it. This will put the tool in the retract mode. To advance the tool, depress the advance button and hold it down. When you are done, depress the stop button and the motor will stop.

NOTE: The pump is still pressurized. To release the air pressure from the pump, put the Air Flow Lever in the OFF position, then depress the advance button on the air remote control. This will purge the air in the motor. Now it is safe to disconnect your air supply line.

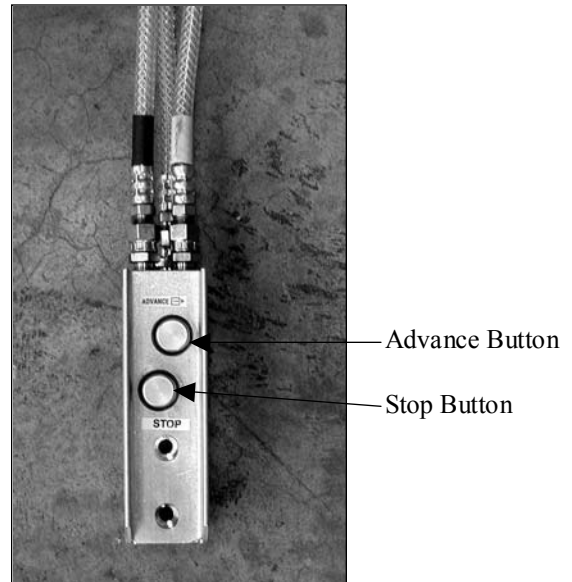

5-6 Operation of automatic pump

Before operating automatic pump, the cable line attached to each hose must be connected securely with the appropriate receptacle on the pump manifold and the receptacle on the tool.

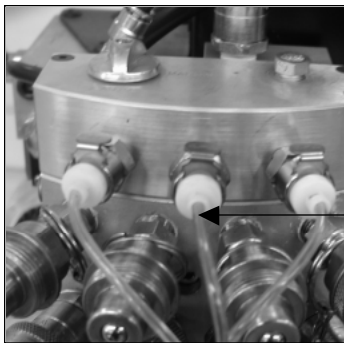

Securely connect



NOTE: Connect only the number of tools used on the application to the pump.

Set pump pressure to achieve desired torque value. (refer to 3-5 and 3-6)

SECTION V

OPERATION – HYTORC Power Packs -continued from the previous page-

5-7 Starting with automatic operation

MANUAL MODE

For manual operation, depress the Mode [M] 3-position rocker switch to the 'MANUAL' position. Hold down the Control [C] rocker switch in the 'RUN' position to advance the tool(s). The switch will toggle to the 'NEUTRAL' position when released, retracting the tool(s). Depress the Control [C] switch to the 'OFF' position to turn off the system.

AUTOMATIC MODE

Initialize Computer:

To operate the automatic system, the computer has to recognize how many tools are attached to the system. To accomplish this, attach the required number of tools to both hydraulic and electric lines. Then cycle system in manual mode for at least one full cycle.

AUTOMATIC TIGHTENING MODE

Initialize the computer (see above). Without shutting pump off, push Mode switch [M] into 'TIGHTENING' position. Press and hold control switch [C] in 'RUN' position. As long as the run switch is held depressed, the pump will function in automatic tightening mode. The tool(s) will continue to cycle until the preset torque is achieved. Allow sufficient time to be sure that the tool(s) have stopped rotating before releasing the run switch. The pump motor will automatically shut off after 20 seconds, allowing the tool(s) to return to the retract position. The 'OFF' position on the Control switch turns off the system.

AUTOMATIC LOOSENING MODE

Initialize the computer (see above). Without shutting pump off, push Mode switch [M] into 'LOOSENING' position. Press and hold control switch [C] in 'RUN' position. As long as the run switch is held depressed, the pump will function in automatic loosening mode. The tool(s) will continue to cycle until the Control switch is released. Cycle tool(s) until nuts are free and can be removed by hand. Release the Control switch and depress the Control switch to the 'OFF' position to complete the loosening cycle.

